



# Transamerica Pyramid Building

## 1 MW CCHP System

### Site Description

The Transamerica Pyramid Building at 600 Montgomery Street is the tallest and most recognizable building in the San Francisco skyline. Built on the former location of the historic Montgomery Block, construction was completed in 1972. The 48-story building houses office and retail space, although is no longer the headquarters of Transamerica Corporation for which the building is named.

### Project Profile

The on-site Combined Cooling, Heating and Power (CCHP) system eliminates demand for city steam and reduces demand for electricity from the utility. Using less electric power during peak times enables the building to buy power at a lower average rate.

Installed in 2007, this CCHP system is comprised of 1 MW of cogen units in total (two 500-kW Waukesha engines) along with a 320-ton absorption chiller. The system is now being maintained by Endurant Energy and is owned and operated by Transamerica Pyramid Properties, LLC.

### Financial Incentives and Performance

Public funding was provided through the California Public Utility Commission's (CPUC) Self-Generating Incentive Program, which paid for 13% of the capital costs. The system produces a combined electrical and thermal efficiency of approximately 50%. The engine itself runs at 27% overall electrical conversion efficiency. An additional 23% is achieved using the recovered waste heat for building water and space heating and cooling. The system operates at near capacity for maximum efficiency and provides approximately 70% of the complex's annual electricity demand.

The captured heat displaces 100% of the steam formerly provided by San Francisco's steam utility. The installation is required by interconnection agreement to power down upon grid failure, but could in the future be upgraded for blackout ride-through capability.

### Quick Facts

**LOCATION:** San Francisco, California

**MARKET SECTOR:** High-Rise Development

**TOTAL PROJECT COST:** \$3.4 Million

**PAYBACK PERIOD:** 4 to 5 years (simple payback with incentives)

**ANNUAL ENERGY BILL SAVINGS:** No Data

**EQUIPMENT:** 1 MW (two 500-kW Waukesha VGF L36GSID natural gas-fired V-12 engine systems)

**FUEL:** Natural gas

**USE OF THERMAL ENERGY:** Providing heating, cooling, and electricity-71% of electricity (some for the displaced cooling), and 100% of steam demand

**FACILITY SIZE:** 2500 square feet

**FACILITY PEAK LOAD:** 2.1 MW

**FACILITY AVERAGE LOAD:** 1.4 to 1.6 MW

**CHP IN OPERATION SINCE:** 2007

### Absorption Chiller



The vast majority of the combustion heat the generator goes to power the York chiller. This single, freight car-sized component is so massive that the floors of the basement room where it is installed had to be reinforced prior to the installation.

Walls were built around the chiller once in place. The York unit has a 500-ton cooling capacity operating on steam, and in this case, a 320-ton capacity operating on the heated jacket water and recovered waste heat from the exhaust of the gen-sets.

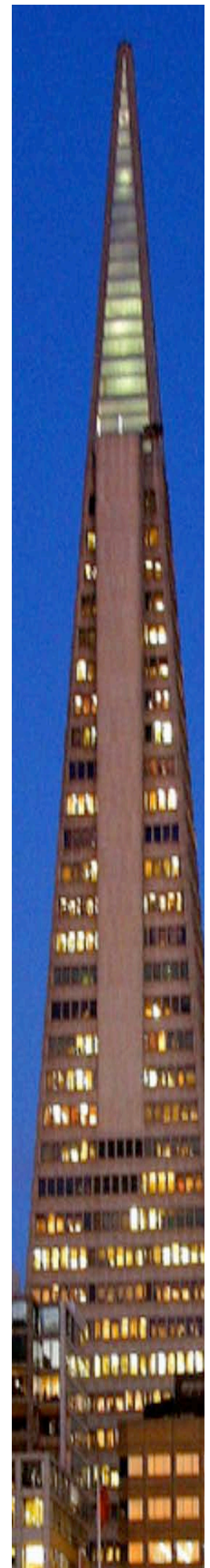
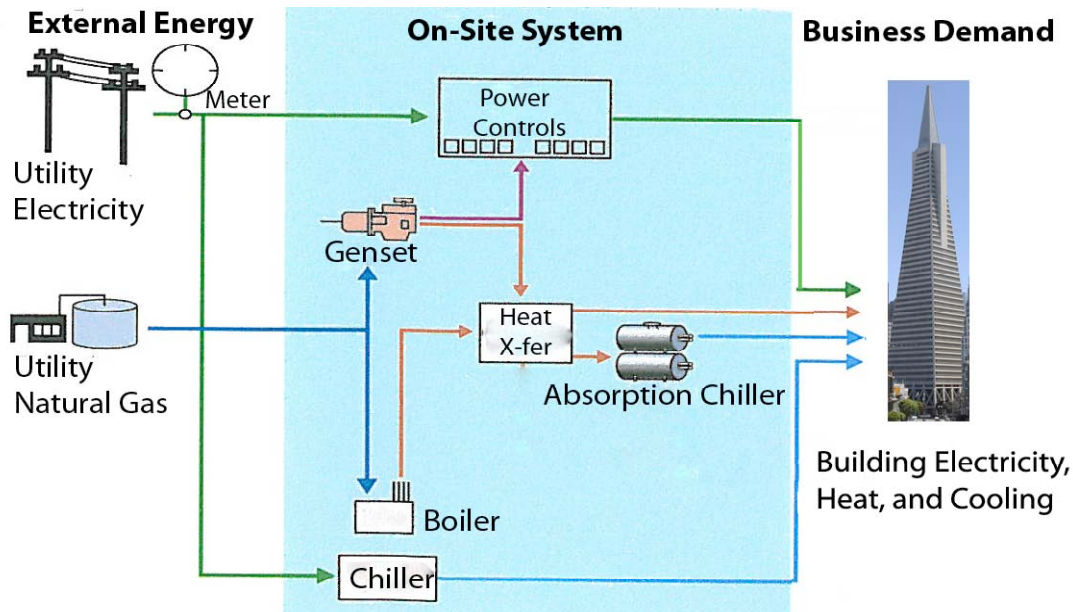

## Installation Challenges

Locating the Transamerica's CHP system in the basement was assuredly going to require supplementary cooling to remove the unused waste heat from the building. Before installation, two large cooling towers served the facility, and the proposed CCHP system would have required a third at street level as the plans were initially drawn. However, both the SF city planning department and the owner of the building thought it better to preserve the historic building's aesthetics, so an electrical compressor chiller to reject waste heat from the CHP unit now serves to cool the basement rooms housing the gensets. The space to locate the absorption chiller close to the cogen unit was not available, so heat is transferred from the cogen unit via the jacket water traveling the perimeter of the underground parking unit to the York chiller located across the building and one floor away. Exhaust emissions from burning natural gas can be a concern in urban environments, and in this installation a three-way catalyst is used to clean up air pollutant emissions to meet the 2007 Bay Area Air Quality Management District's standards.

### York Absorption Chiller



## For More information

Pyramid Building:

[http://en.wikipedia.org/wiki/Transamerica\\_Pyramid](http://en.wikipedia.org/wiki/Transamerica_Pyramid)

Endurant Energy: <http://www.endurantenergy.com>

Additional CHP Pacific Projects Profiles:

<http://www.pacificcleanenergy.org/>

Date Revised: 11/30/10

**U.S. DOE Pacific Region Clean Energy Application Center**

Tim Lipman

2150 Allston Way, Suite 280

Berkeley, CA 94704

[telipman@berkeley.edu](mailto:telipman@berkeley.edu)

